

SUNDT

A U T O C L A V E S

Steam & Waterspray Pilot Retorts

TYPES AP-95 (STATIC) AND APR-95 (ROTARY)



For R&D of new foods in new packages

- Testing of pasteurisation, sterilisation and cooking of food products in any type of container
- Small production or pre-series between 40/60 kg of product per batch
- Specially suited for pouches and flexible trays
- Monitoring and printing of product core temperature and accumulated F-value
- View window with light for package vision during process
- Working methods:
 - Waterspray (water heated in plate heat exchanger)
 - Direct steam + waterspray
 - Direct steam
 - Water immersion

CE

TECHNICAL DATA:

Types:

**AP-95
STATIC**

**APR-95
ROTARY**

Tray size (mm)	600 x 750	500 x 500
Number of trays	11	9
Capacity*	140	48
Weight (kgs)	900	1200
Installed power (kW)	2,7	3,8
Steam consumption (kg/batch)	36	32
Water consumption (l/batch)	396	209
Compressed air consumption (l/batch)	726	827
Maximum service temperature (°C)	150	150
Steam supply pressure (bar)	5-6	5-6
Water supply pressure (bar)	3-5	3-5

(*) Referenced container: 1Kg can, diam.102, h119 mm

ANCILLARY EQUIPMENT:

- Temperature an F-value printer
- Ellab instruments thermocouples, packing glands and miscellaneous special tools

**STATIC
AP 95**

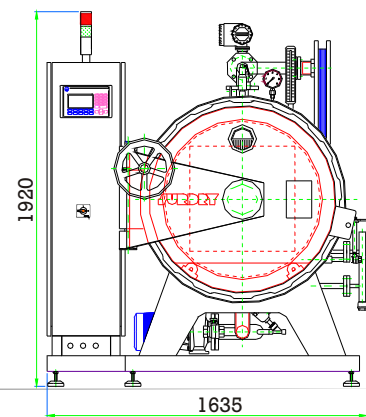
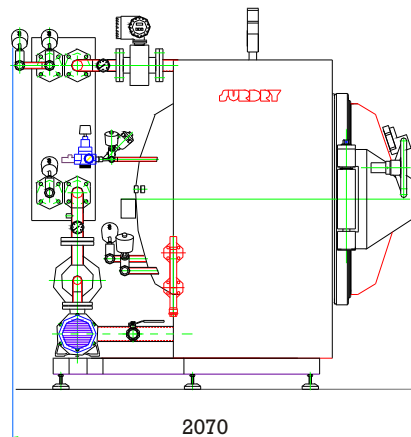

**ROTARY
APR 95**

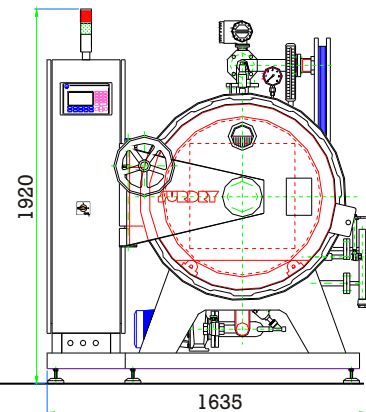
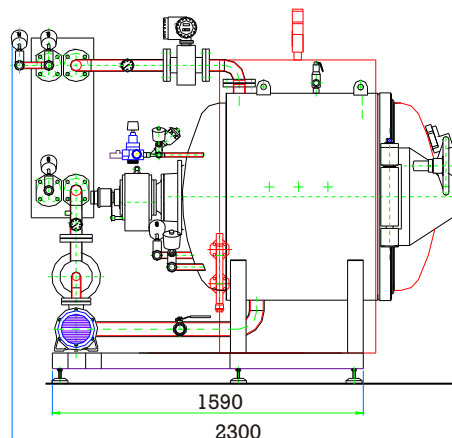

SURDRY
AUTOClaves

For more information, contact our North American distributors:

STOCK

SURDRY S.L.

P.I. Trañapadura · 48220 ABADIANO - Vizcaya , ESPAÑA

Tel. 34 94681 4171 · Fax 34 94681 3452

E-mail: surdry@surdry.com · Web: www.surdry.com

STOCK America Inc. Sterilization Systems Division

2508 Reliance Avenue Apex, NC 27539

Phone 919.362-4444 Fax 919 362-4448

E-Mail: davep@stockamerica.com Web: www.stockamerica.com